



Project Number: 07450

TIGER CLAW PNEUMATIC DECK FASTENER

Sean O’Keeffe
ME

Jon Gardner
Project Manager/ME

James Bagg
ISE

Aaron Wagner
ME

Bokeun Song
ISE

ABSTRACT

Tiger Claw® is recognized as a world leader in the production of hidden deck fasteners aimed at enhancing the natural image of decking woods. They are consistently incorporating new technologies and techniques into their long line of successful products. As the project sponsor, they handed down the task of developing a pneumatic device to accomplish the installation work presently being done by hand. The hope of this project was to create an end product that would eventually be incorporated into their installation process. After much planning, design, and development this team has successfully created a hidden fastener as well as the pneumatic tool charged with firing it. The project specifications set forth by our sponsor have been met with a lightweight, easy to operate tool that effectively fastens decking boards in an inconspicuous manner. Upheaval and strain tests have revealed a product capable of withstanding hurricane force winds and harsh conditions without deviation from the intended design performance. It is with great pride that we complete this phase of development and look forward to future advancements in hidden fastener technology and the possible inclusion of our product.

BACKGROUND

Motivation. In the building industry, contractors are always looking for new and improved methods in order to cut the time and costs of building. Contractors who work with outdoor decking share these same desires. They wish to use the most modern technology that allows them to stay ahead of the competition. Moreover, Tiger Claw® is a leading company in the

hidden deck fastener industry, and is also our sponsor, who would like to have a new unorthodox design for a pneumatic fastener gun. This gun will provide great market share in the deck building industry. The project is a needs based project that will improve upon current deck installation methods, making it a more sensible and efficient operation. There are many types of devices that assist in securing decking boards together, but none that will allow for hidden fasteners and single step operation. A device that can do all this in one step will dramatically reduce the time, effort, and manpower necessary to build a deck. This gun provides a tool that will save time and expenditures for contractors and home owners, and be able to combine multiple tasks into one task. The team’s task was to design, develop and test a pneumatic gun that would be capable of assisting anyone that is going to build a deck.

Sponsor Information. Tiger Claw® sponsored the project in full. The company originally set aside several thousand dollars for the completion of the project. Tiger Claw® has also sponsored a previous senior design project which dealt with the comparison of their products with others on the market.

Tiger Claw® is a small company based out of Bristol, CT that was founded in 1999 by a group of contractors, engineers, and business professionals. The company specializes in hidden deck fasteners for the building industry and is sold at more than 120 retail outlets nationwide.

Benchmarking. The concept of affixing a hidden deck fastener through pneumatic means is a new and novel idea. The market for pneumatic fasteners

currently consists of either staples or nails. Hidden fasteners currently consist of multi-pronged devices that are installed manually. There are presently no tools within today's market that combine both aspects of installation. By combining the power, speed, and efficiency of a pneumatic tool with the aesthetically pleasing strength of a hidden deck fastener, you get a new tool that will one day revolutionize the market is born.

Priorities. The most important part of our project was to make sure that the design we have created be a feasible concept. First off, we need to keep the pneumatic gun consistent with those that are currently on the market. Included were weight, ergonomic design, safety, and ease of use. Also, one of the main goals was to create a process which would allow us to assemble decks at a much faster rate. Our design would have to be much different than current staple guns. By requiring a fastener that is hidden to the human eye from anywhere on the deck surface, the staples must be inserted from underneath the deck. This is a way to guarantee that the fastener is hidden. Also, the person using the pneumatic gun needs to be shooting from the top or above the deck and not have to go beneath it. By accomplishing all of these necessities, the concept's feasibility was confirmed.

There are a few critical subsystems that are within our pneumatic gun design. The first and most important is the pneumatic cylinder. This is what actually fires our staple gun and inserts the staples into the deck boards and joists. This is accomplished through a series of compressed air reservoirs and various valves, such as the exhaust valve and trigger valve. The cylinder drives the piston/shaft combination out and strikes the staple waiting on the track. The track is another critical subsystem since it needs to be altered in order to fit our own staple. This involved the re-machining of most of the parts associated with the track.

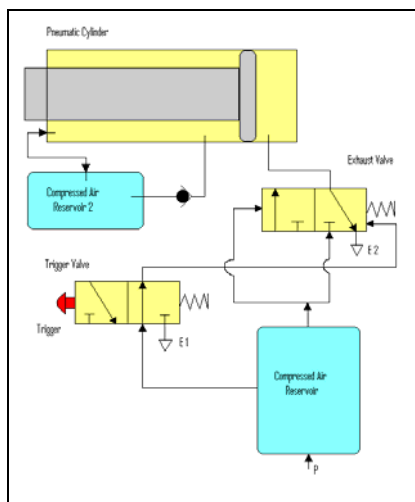

Figure 1: Schematic Showing Pneumatic Flow

Risk analysis was also very important priority. Some possible risks for our project came in re-designing an existing gun. The situation that arose was whether or not the changes that were made affected the internal features and caused them not to work properly? This was looked at in calculations of pressure and momentum within the gun as well as the staple. The design could not infringe on any existing industry designs and should be marketable by Tiger Claw®. Another risk was that the cost of testing the product became expensive because of the process we decided upon for operation.

PROCESS

Theory. The theory behind our project was to create an easy to use pneumatic gun that inserts staples into a deck while keeping them hidden at the same time.

Assumptions. We assumed that the set ups of the decks, that our pneumatic gun used were standard in terms of dimensions of standard decks. Also, we assumed that we would be able to fit our gun underneath the deck in order to fire in the staples.

Customer Needs. There are a specific set of customer needs from Tiger Claw®. These include a faster process for installing the hidden deck fasteners, doing so at a viable cost, making it a single-person process, safe installation, a reliable fastener, and a user friendly gun design. Beginning with the faster process, we wanted to cut current fastener installation time down from 60 seconds to 5 seconds. This would be the total time required to align the tool and fire the fastener into the deck and joist combination. The next customer need, a viable cost, had us look at the current setup for installing the fasteners. Overall, cost of tools are low for current setups, but the cost of labor makes this much higher. Our goal is to have the gun fall between the \$400 and \$500 range in order to keep it relatively comparative to current pneumatic guns. This would be aimed at medium to large size contractors. Since the current process of installing fasteners is a single person process, we want to keep it the same for our pneumatic tool. This would mean that we need to keep the tool lightweight and ergonomically designed for one person to operate. The next customer need was safe installation of the staples. A pneumatic tool is much more dangerous than the current fasteners Tiger Claw uses, since it involves a large amount of pressure within the gun, along with a sharp fastener that gets shot from the track. Also, a pneumatic gun must have some sort of safety capabilities. Currently most guns use either a pressure sensitive safety tip or a double trigger of some type that allows actuation of the cylinder. A reliable fastener is also one of the primary customer needs. As long as the fasteners can hold up to the loads that are put on a deck by way of upheaval, then they should be sufficient. The last

customer need is the pneumatic gun's ease of use. This can be done by making alignment of the fastener simple and quick to set up. The tool should also be easy to remove staple jams as well as easy to clean the gun's internal parts.

Customer Specifications. Customer specifications are also critical aspects to the process of our product. The most important specification is the fastener visibility. The main goal of this project was to create a deck with no fasteners, screws, or staples visible. The next critical specification was the overall dimensions of the pneumatic gun. It needed to easily fit between the joists and deck boards to make for easy installation. From here we needed a quick fire time as well as quick reload. These are crucial to reducing the overall time to put together a deck. The faster that the deck can be built, the quicker the gun will be paid for in profits from building multiple decks. Along with this comes easy maintenance on the gun. This will include using different methods for easy staple jam removal as well as having an easy casing that can be opened in order to fix or change internal parts. Spacing between the deck boards is also consistent at 3/16". Spacing is something that could have been taken care of on our gun, or customers could use an external spacer. Additional specifications would be on the track hardness and the tolerances on the track. Since there will be repeated scraping and force going through this area, the track will need to be hardened to stop material from breaking off, wearing down, or chipping the track. Also, the tolerance of the track is critical because it guides the staple to the insertion point. If there is too much friction between the staple and the track it could cause some major problems. Another one of our main goals is to create this tool with high lifetime expectancy. This is set at around a ten year time period, which most pneumatic parts are expected to last beyond.

Concepts & Evaluation. The concept selection matrix was a tool that was used in order to select the best possible concept. The matrix assigns a weight to the different selection criteria and then draws comparisons between the different concepts. This allows the user to highlight all the strengths and weaknesses of the different designs. With the help of this tool the team was able to create a concept that incorporated the best design features of all the concepts.

Selection Criteria	Weight	(reference)		Original		Helicopter		Poseidon		Penetrator		Originator	
		Rating	Weighted	Rating	Weighted	Rating	Weighted	Rating	Weighted	Rating	Weighted	Rating	Weighted
		Score		Score		Score		Score		Score		Score	
Cost	5%	3	0.15	5	0.25	3	0.15	4	0.2	4	0.2	4	0.2
Installation Time	20%	3	0.6	4	0.8	3	0.6	3	0.6	3	0.6	3	0.6
Upheaval Strength	15%	3	0.45	2	0.3	2	0.3	2	0.3	2	0.3	2	0.3
Gun Weight/Size	5%	3	0.15	4	0.2	3	0.15	4	0.2	4	0.2	3	0.15
Ease of Use	15%	3	0.45	2	0.3	5	0.75	4	0.6	4	0.6	4	0.6
Magazine Size	5%	3	0.15	2	0.1	3	0.15	3	0.15	3	0.15	3	0.15
Fastener Visibility	20%	3	0.6	3	0.6	5	1	3	0.6	3	0.6	3	0.6
Easy Gun Removal	15%	3	0.45	5	0.75	4	0.6	5	0.75	5	0.75	5	0.75
Total Score			3.00		3.30		3.70		3.40		3.35		3.35
Rank			5		4		1		2		3		3

Figure 2: Concept Selection Matrix

The quality function diagram (QFD) is a tool that draws comparisons between the customer requirements and the engineering specifications. A weight is assigned the customer requirements and a number is placed in the matrix regarding the correlation between the desires of the customer and the specifications of the engineer. From the QFD the senior design team was able to determine the most important subsystems on the project.

Customer Requirements	Customer Weights	Durable	Time between installing two fasteners	Pressure Requirements	Large Range of Operating Temperatures	Weight	Ergonomic Rating	Industrial Design Customer Acceptance Rating	Staple Volume Capacity	Noise Level	Time to reload magazine	Customer Maintenance Rating	Accepts multiple staple sizes	Fastener Envelope Volume	Operates on acceptable range of decking materials	Design for Lifetime	Manufacturability
1 Acceptable force to adhere staple	9	3	3	9	9												
2 Process faster than current procedures	9			9	9												
3 Drives multiple types of staples	3			3										9	9		
4 Stapler feels good in user's hand	3					9	9					3					
5 Stapler is lightweight	3		1			9	9	1									
6 Stapler is safe to use	9			1	1	9			3								
7 User can handle stapler recoil	3		1	9	3	3						9					
8 Can control the pressure settings	3			9	1							3		1	3		
9 Stapler is easy to set up	9		3								3						
10 Stapler is easy to use	9		9			3	9										
11 Stapler is easy to maintain	9		3	3							3		9	1	9		
12 Stapler is long lasting	9		9									3			9		
13 Stapler is quiet	3			3			9			9	1						
14 Stapler looks good	1							9							1		
15 Stapler can hold large volume	9					3		9		9			3	1			
16 Stapler is affordable for contractors	3															1	
17 Stapler metals hidden fasteners	9																

Figure 3: Quality Function Diagram

Analysis. The design of the piston size was based on hand calculations that would allow normal operating pressures between 80 psi and 120 psi and a maximum operating pressure of 150 psi.

$$A = \pi * r^2$$

$$A = \pi * \left(\frac{1.56in}{2}\right)^2 = 1.9113in^2$$

$$P = \frac{F}{A}$$

$$F_{O,Min} = \left(80 \frac{lb}{in^2}\right) * 1.9113in^2 = 153lbs$$

$$F_{O,Max} = \left(120 \frac{lb}{in^2}\right) * 1.9113in^2 = 229.4lbs$$

$$F_{Max} = \left(150 \frac{lb}{in^2}\right) * 1.9113in^2 = 286.7lbs$$

Force on Staple/Hammer: 153lbs – 229.4lbs
 Max Force on Staple/Hammer: 286.7lbs

Impulse of Staple

$$I = Ft = (m_{piston} + m_{staple})\Delta V$$

$$V = \frac{\Delta x}{\Delta t}$$

$$V = \frac{1inch}{.01sec} = 8.33ft / s$$

$$I = (.332018lbm)8.33ft / s = 89.11(lbf * ft / s)$$

For finite element analysis (FEA), ANSYS software was used to predict the Von Mises stresses and deflection in the high friction areas of the pneumatic gun at maximum operating pressure. In particular, the piston shaft (see Fig. 4) and fastener (see Fig. 5).

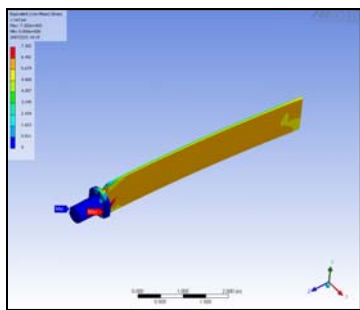

Figure 4: Von Mises Stress in Piston Shaft with Deflection

The maximum Von Mises Stress found in the piston shaft was 7.3 ksi with 1015 tool steel. The yield strength for 1015 tool steel is 47.1 ksi according to MatWeb, which is well above the Maximum Von Mises found. Since there is a slight deflection in the shaft (.00236 in.) under these forces, a guide will be used to constrain the side to side movement of the shaft.

The ANSYS program was also used to determine what deformation and Von Mises stresses would occur during the impact of the staple through the wood surfaces. Applying the forces calculated on impulse loads the program predicted a maximum Von Mises Stress of 26.1 ksi and a deflection of .0014 inches. The deflection is extremely low for the purpose that it is required so that can be negligible. The Maximum Von Mises Stress is below the yield strength of 304 SS, which is 32.2 ksi according to MatWeb. This shows that the fastener design should be suitable for its intended purpose.

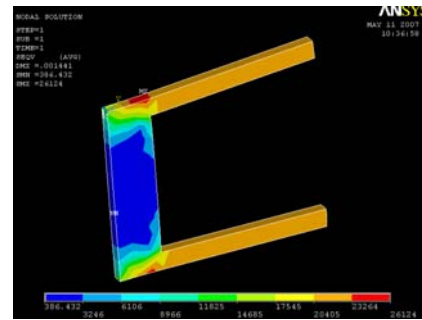

Figure 5: Von Mises Stress in Staple with Deflection

To predict the Von Mises Stress and deformation that the fastener will endure due to upheaval, ANSYS was used applying varying hurricane category levels. A base category level 5 hurricane has wind speeds of 156 mph according to FEMA. This can be approximated as an applied load of 157.4 lbf. With this load applied to a single fastener the maximum Von Mises Stress is 38957psi (see Fig. 6) according to ANSYS. This is above the yield tensile strength of steel which is 31200psi but well below the ultimate tensile strength of 73200psi. In order to ensure that the fastener withstands these forces two fasteners should be placed into every joist and deck board intersection.

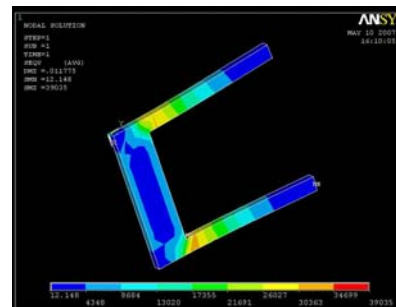

Figure 6: Von Mises Stress and Deflection in Fastener

Ergonomics. Ergonomic design can help optimize human performance by ensuring that the hand tools support the task needs as well as the human capacity. Specifically, ergonomic design guidelines have been developed that ensure job demands do not exceed human capabilities. By using lifting analysis, recommended work lifting can be found and compared with 90 percent of an average American’s capability based on NIOSH (National Institute of Occupational Safety and Health) administration.



Figure 7: Hand Placement on Pneumatic Gun

Prior to the assessment, it must determine if the job is single or multi-task manual lifting job. Secondly, it must determine if significant control is required at the destination of the lift. The lifting jobs in the workplace could be analyzed as a single-task lifting job since many of the lifting jobs in the workplace have repetitive lifting activities, like our deck fastener gun. To perform a lifting analysis using the revised lifting equation, two steps are undertaken: 1) data is collected at the worksite and 2) the Recommended Weight Limit (RWL) and Lifting Index values are computed using the single-task analysis procedure.

1. Weight of the object lifted.
2. Horizontal and Vertical locations of the hands with respect to the mid-point between the ankles.
3. Angle of asymmetry at the origin and destination of the lift.
4. Determine the average lifting frequency rate(F), in lifts/min, periodically throughout the work session(average over 15mins period)
5. Lifting duration can be determined the total time engaged in continuous lifting and the schedule of recovery allowances for each lifting task.

This Analysis shows that both the Lifting Index (LI) is less than 3 which indicates that there is no high risk of developing low-back pain or injuries from workers base on National Institute of Occupational Safety and Health (NIOSH) standard.

Building. Pro E was used to construct a CAD model of the selected pneumatic gun concept (see Fig. 8) and fastener concept (see Fig. 9). This gave exact dimensions to the many parts that would make up the product. Due to time and cost constraints a second CAD model was created that would install the fastener for all testing purposes. This design consisted of a pneumatic gun that fired a fastener into the deck board and joist (similar to original design but without clamping mechanism). This allowed for variation in the testing with both the fastener and the tip of the pneumatic gun.

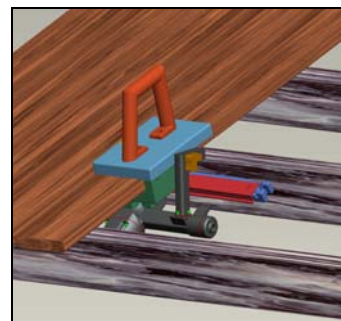

Figure 9: CAD drawing of Pneumatic Gun on Deck

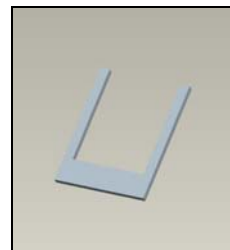

Figure 10: CAD drawing of Single Fastener/Staple

JOB ANALYSIS WORKSHEET											
DEPARTMENT				Senior Design II, P. 7-60				JOB DESCRIPTION			
JOB TITLE											
ANALYST'S NAME											
DATE											
STEP 1. Measure and record task variables											
Object Weight (lb)	Hand Location (in)				Vertical Distance (in)	Asymmetric Angle (degrees)		Frequency (lifts/min)	Time (min)	Duration (min)	Dist. Coupling
	L (W/O)	L (W/C)	H	V		H	V				
15	15	5	10	20	30	0	0	.033	4	fair	
STEP 2. Determine the multipliers and compute the RWL's											
RWL = LC · HM · VM · DM · AM · FM · CM											
ORIGIN		RWL = 6.1 · [2] · [1.85] · [1.88] · [1] · [1.27] · [1.95] = 19.57 Lbs									
DESTINATION		RWL = 6.1 · [1.5] · [1] · [1.88] · [1] · [1.27] · [1] = 6.1 Lbs									
STEP 3. Compute the LIFTING INDEX											
ORIGIN		LIFTING INDEX = OBJECT WEIGHT (L) / RWL = 15 / 19.57 = .76									
DESTINATION		LIFTING INDEX = OBJECT WEIGHT (D) / RWL = 15 / 6.1 = 2.4									

Figure 8: Single Task Job Analysis Worksheet

To construct the tool used to install the fastener a pneumatic staple gun manufactured by Senco® was purchased and then the piston and staple track were altered. The parts making up the staple track and piston shaft were made by machinists at R. J. Precision because of their complex geometry. These parts were all made of 1016 tool steel because it is relatively easy to machine and gave the tool a rugged design for high friction areas of the gun. The staples were made by Rintec® using a water jet to cut out the profiles. These fasteners were made of 304, annealed, stainless steel because it is a low grade steel that is weather resistant.

Upon receiving these parts back from the machinists several other parts currently on the gun had to be machined in order to integrate everything. This was

accomplished by team members using the machine shop on the RIT campus.

Four test decks were built to test the fastener strength against upheaval forces. Two of the test decks consisted of three joists which were spread 12 inches on center and the other two decks consisted of three joists that were spread 16 inches on center. In order to set up this test some steel blocks also had to be machined that would invert the test decks and allow a load to be placed on the bottom. Also the frame for a 25 ft² deck was built to be used in additional tests. The decking materials that were purchased consisted of pressure treated pine, Trex (Medium Density Composite), and TimberTech (High Density Composite). Composite material is used in higher quality decks and consists of a mixture of various woods and plastics.

Testing. The hardness of the staple was taken using a Rockwell B test in the Materials Science Lab at RIT. The average hardness found was 81.5 which give a tensile strength of 7.3 ksi. According to MatWeb for AISI 304 stainless steel the tensile strength is 7.32 ksi. This confirms the material properties of the fastener.

In order to simulate upheaval forces on the deck, the four test decks mentioned previously in the building section were constructed with a single deck board fastened to the frames. There were 8 fasteners placed in each test deck to hold the board onto the frame. The deck was then inverted and placed onto the 4 machined blocks mentioned previously in the building section. Using the Tinius Olsen Load Cell a distributed load was placed over the deck board to simulate a wind (upheaval) load. The computer recorded the upheaval force every second until a failure occurred. Failure criteria consisted of the deck board being separated from the frame due to either the fasteners coming out or the decking materials breaking.

In order to get a better idea of how the pneumatic tool would work on an actual deck, the 25 ft² (5 ft x 5 ft) deck mentioned in the building section was used. All team members were given the chance to install fasteners using the tool. The deck boards used on this frame were pressure treated pine, Trex, and TimberTech. All three materials were distributed evenly on the deck. Upon completion of this deck a manual inspection of performances was conducted by members of the team.

Ergonomic testing was done by making an actual size foam model to have full grasp on what is the ideal position for human to place their hands. Moreover, it guided where the location of the handle could be implemented for most comfortable position. By changing the shape and diameter of the handle in foam

model, it was determined that round shape with power grip of 1.6 inches in diameter was most desirable. The pneumatic staple gun is shooting at a 45 degree angle between the joist and deck board, which eliminates the hazards of misfiring by people. The clamping mechanism will also eliminate the recoil of the pneumatic gun and the gun will also slide between the joists, which reduces the stress of muscle fatigue if it were to be lifted up every time.

RESULTS & DISCUSSION

Final Product. The final design for the tiger claw pneumatic hidden deck fastener incorporates both a solid fastener and original gun design. Both of these products have innovative ideas and a good market base driving the design. The combination of drivers will allow Tiger Claw to sell a gun, or the intellectual property rights, and the fastener as a part of its growing market. This gun takes into consideration all of the normal pneumatics customer needs, but also breaks into new markets as a speed improvement over other systems. The gun is a hand held, pneumatically driven, single operator tool formed into a c-clamp shape that is easy to use, quickly and safely.

Specifications Met. There were five main specifications for the design of this gun/fastener combination: a short installation time, good upheaval strength of fastener, affordability, ergonomically sound, and a durable system, all of which were touched on earlier.

The system itself was able to come inside of the time constraints set for installation. The current system ran with an approximate installation time of 1 minute per fastener, the current system factoring in any wait time for the air compressor used for pneumatic power to the gun and placement of the gun can install in under 10 seconds per fastener. This presents the considerable time and cost savings that were a big part of what made this project viable and important to the deck building industry.

Upheaval strength is a key component and is also a factor of safety associated with the project. The upheaval tests were a great success; all of the tests on our four small decks with a variety of the most commonly used decking materials passed. The strength of the fasteners was tested in terms of hurricane levels and each passed levels 1 through 5 (see Fig.10), this allows them to be sold by Tiger Claw without restriction in specific locations.

Material	Hurricane Loading Comparison						
	On Center Span in	Max Force Per 8 Fasteners lbf	Hurricane Level				
			1	2	3	4	5
Trex	12	382.2	Pass	Pass	Pass	Pass	Pass
TimberTech	12	187.47	Pass	Pass	Pass	Pass	Pass
Pressure Treated Pine	16	256.188	Pass	Pass	Pass	Pass	Pass
Trex	16	187.011	Pass	Pass	Pass	Pass	Pass

Figure 11: Hurricane Load Comparison Chart

Evaluation of Success. A successful project should meet all of the specifications and needs of the customer and market base. The gun/fastener combination was shown to accomplish all of the major deliverables, keeping the customer goals in mind, and in this regard it was a great success. Some higher level goals were found not to be within the reasonable bounds of the project as far as the design time allotted. The full working model was not able to be manufactured because of the expense of the prototype and the time required for machining. However, with the wide usability of the fastener with decking materials, the establishment that a fastener will secure a deck from below the deck surface, and the practicality of the gun with regard to cost this project can be looked at as a great success.

Reproduction of Design. The design was modeled in Pro E and other existing pneumatic tools were examined for design considerations in coming up with a feasible gun design. The gun is well within the bounds of normal fabrication techniques such as part casting, die forming, and material welding etc.

CONCLUSIONS & RECOMMENDATIONS

Project 07450 can easily be characterized as a successful endeavor in both design and implementation. The goal of this venture was to create a hidden fastening device for decking boards as well as the pneumatic tool capable of firing it. Both of these objectives have been completed on time, within budget and with customer approval. This fully functional prototype is an end product for this particular work phase, but only the beginning for the pneumatic fastener concept. Our product is a stepping stone and was designed with the notion that future advances in hidden fastener technology will be built upon the work we have done. Moments of success and failure are a natural part of the design and

implementation process. This project is not unlike any other and suffered several delays and setbacks. The important point to take away from this project as a whole, is the fact that groundwork has been laid. Areas where our product falters can be studied and improved upon in future generations of design. It is the hope of this design team that the group who carries on from this point will enhance the gun’s cradle features and stay true to the firing methods we have developed. The geometry of the staple can also be optimized by placing tip conditions on the prongs and a radius at the base of the prongs. In any event, the Senior Design Team of Project 07450 looks back fondly upon this project and all aspects of its production. Additionally, we look forward to the anticipated bright future of this project and the potential success to be gained from it on behalf of our sponsor Tiger Claw®.

ACKNOWLEDGMENTS

The team members of Senior Design project number 07450 would like to give special thanks to our sponsor Tiger Claw, our advisor Dr. James Taylor, R. J. Precision, Rintec, Bill Morris, Steve Kosciol, Robert Kraynik, and Tim Landschoot.

REFERENCES

[1] MatWeb, 2007, “AISI 1015 Steel, Cold Drawn,” Automation Creations, Inc., <http://www.matweb.com>.
 [2] FEMA, 2006, “Learn About Hurricanes,” U.S. Department of Homeland Security, Dave Hathaway, http://www.fema.gov/hazard/hurricane/hu_about.shtm#1.
 [3] EDGE Website, 2007, Rochester Institute of Technology, <http://edge.rit.edu/>.
 [4] Wickens, Christopher D., Introduction to Human Factors 2nd ed. New Jersey: Prentice Hall
 [5] National Institute for Occupational Safety and Health, www.cdc.gov/niosh.
 [6] Beer, Ferdinand P., and E. Russell Johnston Jr. Vector Mechanics for Engineers: Dynamics. 5th ed. New York: McGraw-Hill Book Company.

Tiger Claw hidden deck clip fasteners work with a variety of grooved boards including hardwoods and IpÃ©, softwoods like cedar and redwood, pressure treated, PVC and composite decking.Â Keyword. TigerClaw Hidden Fastening. TC-G Grooved Board Hidden Fastener. For grooved boards. View Details. TC-120 Grooved Board Hidden Deck Fastener for Hardwood. For grooved hardwoods. View Details. Tiger Claw Installation Gun for Grooved Decking. Installation gun for grooved decking. View Details. Tiger Claw Pneumatic Scrails for Installation Gun. For use with the Tiger Claw Installation Gun. View Details. Tiger Claw Slot Cutters. For cutting grooves into square edge decking. View Details. The Tiger Claw TC-G clip system is the fastest, easiest way to hide fasteners on grooved decking. It has been specifically designed to work in 5/4" or greater x 4" or 6" decking that is pre-grooved or grooved with the TC-150 slot cutter. The TC-G is made of 304 grade stainless steel and is approved for use in saltwater applications and ACQ or chemically treated lumber for long-term performance. The clip's sharp prongs embed into the upper portion of the groove for strong holding power.Â I bought this one and used the Tiger Claw gun. I personally don't see how the screw versions can get the boards tight and keep them tight. I did most of a Trex deck by myself 14x32 took me 2 days. If i had to drive every screw with an impact I cant even imagine how long it would have taken me! TigerClaw Coated Steel Pneumatic Scrails Fasteners - 930 pcs. for approx. 500 square feet - TC-SG. 4.7 out of 5 stars 16.Â Tiger Claw TC-4S Stainless Steel Hidden Deck Fastener for Hardwoods and Ipe, 90 Pieces (F-4534-T490). \$72.87\$72.87. FREE Shipping. More Buying Choices \$59.00 (6 new offers). Tiger Claw TC-120 Hidden Deck Fasteners for Grooved Boards (90 pieces with screws). Tiger claw TC-3 hidden deck fastener - 2 boxes total (100 fasteners/box). Condition: New. Approx.Â "This is for two boxes (100 fasteners/box) of Tiger Claw TC-3 fasteners. Each box also includes the plastic installation block. If you are planning a composite deck project, you will not want to miss out on this deal !" See allItem description. About this item. Postage, Returns & Payments. Best-selling in Other Fasteners. Falcon Tapping Screw Kit - Pack of 120. 3.8 out of 5 stars based on 8 product ratings(8). Learn about hidden deck fasteners at Decks.com.Â Tiger Claw: Fastenmaster manufactures a variety of stainless steel clips that fit in between deck boards to create a fastener free decking surface. The TC-G Grooved Board Hidden Deck Fastener works with grooved deck boards and non-grooved deck boards using the TC-150 slot cutter. This clip works with Trex Select, Evergrain, ChoiceDeck, Fiberon Horizons, Pro-Tect, Paramount, Wolf PVC, Island, Moistureshield, Tuf-Dek, Veranda Armorguard composites and most pre-grooved exotic hardwoods.Â The Tiger Claw Pneumatic Installation Gun holds the Tiger Claw clips in place while driving a screw to secure decking. You can install about 400 square feet per hour using this tool. Tiger Claw. Concealoc Hidden Fastener.