

Reflection and its Use: From Science to Meditation

Hendrik Barendregt
Nijmegen University
The Netherlands

The phenomenon of *reflection* will be introduced and clarified by examples. Reflection plays in several ways a fundamental rôle for our existence. Among other places the phenomenon occurs in life, in language, in computing and in mathematical reasoning. A fifth place in which reflection occurs is our spiritual development. In all of these cases the effects of reflection are powerful, even downright dramatic. We should be aware of these effects and use them in a responsible way.

Reflection: domain, coding and interaction

Reflection occurs in situations in which there is a *domain* of objects that all have *active meaning*, i.e. specific functions within the right context. Before turning to the definition itself, let us present the domains relevant for the four examples. The first domain is the class of proteins. These have indeed specific functions within a living organism, from bacterium to *homo sapiens*. The second domain consists of sentences in natural language. These are intended, among other things, to make statements, to ask questions, or to influence others. The third domain consists of (implemented) computable functions. These perform computations—sometimes stand alone, sometimes interactively with the user—so that an output results that usually serves us in one way or another. The fourth domain consists of mathematical theorems. These express valid phenomena about numbers, geometric figures or other abstract entities. When interpreted in the right way, these will enable us to make correct predictions.

Now let us turn to reflection itself. Besides having a domain of meaningful objects it needs *coding* and *interaction*. Coding means that for every object of the domain there is another object, the (not necessarily unique)

code, from which the original object can be reconstructed exactly. This process of reconstruction is called *decoding*. A code C of an object O does not directly possess the active meaning of O itself. This happens only after decoding. Therefore the codes are outside the domain, and form the so-called *code set*. Finally, the interaction needed for reflection consists of the encounter of the objects and their codes. Hereby some objects may change the codes, after decoding giving rise to modified objects. This process of *global feedback* (in principle on the *whole* domain via the codes) is the essence of reflection.

It should be emphasized that just the coding of elements of a domain is not sufficient for reflection. A music score may code for a symphony, but the two are on different levels: playing a symphony usually does not alter the written music¹.

Examples of reflection

Having given this definition, four examples of reflection will be presented.

1. **Proteins.** The first example has as domain the collection of proteins.



¹However, in aleatory music—the deliberate inclusion of chance elements as part of a composition—the performance depends on dice that the players throw. In most cases, the score (the grand plan of the composition) will not alter. But music in which it really does alter is a slight extension of this idea.

Fig. 1. A schematic display of the protein NGF_Homo_Sapiens, a nerve growth factor. Its three dimensional structure can be perceived by looking at the picture with crossed eyes such that the left and right images overlap. Courtesy of the Swiss Institute of Bioinformatics, Peitsch et al. [1995].

<ftp://ftp.expasy.org/databases/swiss-3dimage/IMAGES/JPEG/S3D00467.jpg>

Each protein is essentially a linear sequence of elements of a set of 20 amino acids. Because some of these amino acids attract one another, the protein assumes a three dimensional shape that provides its specific chemical meaning. To mention just two possibilities, some proteins may be building blocks for structures within or between cells, while other ones may be enzymes that enable life-sustaining reactions. The code-set of the proteins consists of pieces of DNA, a string of elements from a set of four ‘chemical letters’ (*nucleotides*). Three such letters uniquely determine a specific amino acid and hence a string of amino acids is uniquely determined by a sequence of nucleotides, see Alberts et al. [1993]. A DNA string does not have the meaning that the protein counterparts have, for one thing because it has not the specific three dimensional folding.

The first advantage of coding is that DNA is much easier to store and duplicate than the protein itself. The interaction in this example is caused by a modifying effect of the proteins upon the DNA. This is also a second advantage of the protein coding, providing the possibility of change, to be described later.

Protein: 241 amino acids; molecular weight 26987 Da.						
www.ebi.ac.uk/cgi-bin/expasyfetch?X52599						
MSMLFYTLIT	AFLIGIQAEP	HSESNVPAGH	TIPQVHWTKL	QHSLDTALRR	ARSAPAAAIA	60
ARVAGQTRNI	TVDPRLFKKR	RLRSRVLFS	TQPPREAADT	QDLDFEVGGA	APFNRTHRSK	120
RSSSHPIFHR	GEFSVCDSVS	VWVGDKTTAT	DIKGKEVMVL	GEVNINNSVF	KQYFFETKCR	180
DPNPVDSGCR	GIDSKHWNSY	CTTHTFVKA	LTMDGKQAAW	RFIRIDTACV	CVLSRKAVRR	240
A						241

Tabel 1. Amino acid sequence of NGF_Homo_Sapiens.

ACGT-chain: length 1047 base pairs.						
www.ebi.ac.uk/cgi-bin/expasyfetch?X52599						
agagagcgct	gggagccgga	ggggagcgca	gcgagttttg	gccagtggtc	gtgcagtcca	60
aggggctgga	tggcatgctg	gacccaagct	cagctcagcg	tccggacca	ataacagttt	120
taccaaggga	gcagctttct	atcctggcca	cactgaggtg	catagcgtaa	tgtccatgtt	180
gttctacact	ctgatcacag	cttttctgat	cggcatacag	gcggaaccac	actcagagag	240
caatgtccct	gcaggacaca	ccatccccca	agtccactgg	actaaacttc	agcattccct	300
tgacactgcc	cttcgcagag	cccgcagcgc	ccggcagcg	gcgatagctg	cacgcgtggc	360
ggggcagacc	cgcaacatta	ctgtggaccc	caggctgttt	aaaaagcggc	gactccgttc	420
accccgtgtg	ctgtttagca	cccagcctcc	ccgtgaagct	gcagacactc	aggatctgga	480
cttcgaggtc	ggtggtgctg	cccccttaa	caggactcac	aggagcaagc	ggtcatcatc	540
ccatcccatc	ttccacaggg	gccaattctc	ggtgtgtgac	agtgtcagcg	tgtgggttgg	600
ggataagacc	accgccacag	acatcaaggg	caaggaggtg	atggtgttgg	gagaggtgaa	660
cattaacaac	agtgtattca	aacagtactt	ttttgagacc	aagtgccggg	accctaatcc	720
cgttgacagc	gggtgccggg	gcattgactc	aaagcactgg	aactcatatt	gtaccacgac	780
tcacaccttt	gtcaaggcgc	tgaccatgga	tggcaagcag	gctgcctggc	ggtttatccg	840
gatagatacg	gcctgtgtgt	gtgtgctcag	caggaaggct	gtgagaagag	cctgacctgc	900
cgacacgctc	cctccccctg	ccccttctac	actctcctgg	gccccctcct	acctcaacct	960
gtaaattatt	ttaaattata	aggactgcat	ggtaatttat	agtttataca	gttttaaaga	1020
atcattattt	attaaatfff	tggaagc				1047

Tabel 2. DNA code of NGF_Homo_Sapiens.

A simple calculation ($1047/3 \neq 241$) shows that not all the letters in the DNA sequence are used. In fact, some proteins (RNA splicing complex) make a selection as to what substring should be used in the decoding toward a new protein.

2. Natural language. The domain of the English language is well-known. It consists of strings of elements of the Roman alphabet extended by the numerals and punctuation marks. This domain has a mechanism of coding, called *quoting* in this context, that is so simple that it may seem superfluous. A string in English, for example

Maria

has as code the quote of that string, i.e.

‘Maria’.

In Tarski [1933/1995] it is explained that of the following sentences

1. Maria is a nice girl
2. Maria consists of five letters

3. 'Maria' is a nice girl
4. 'Maria' consists of five letters

the first and last one are meaningful and possibly valid, whereas the second and third are always incorrect, because a confusion of categories has been made (Maria consist of cells, not of letters; 'Maria' is not a girl, but a proper name). We see the simple mechanism of coding, and its interaction with ordinary language. Again, we see that the codes of the words do not possess the meaning that the words themselves do.

3. Computable functions. A third example of reflection comes from computing. The first computers made during WW2 were *ad hoc* machines, each built for a specific use. Since hardware at that time was a huge investment, it was recycled by rewiring the parts after each completed job. Based on ideas of Turing, this procedure was changed. One particular computer was constructed, the *universal machine*, and for each particular computing job one had to provide two inputs: the instructions (the software) and the data that this recipe acts upon. This has become the standard for all subsequent computers.

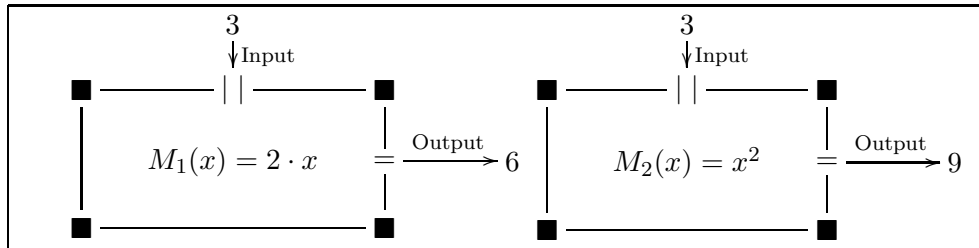
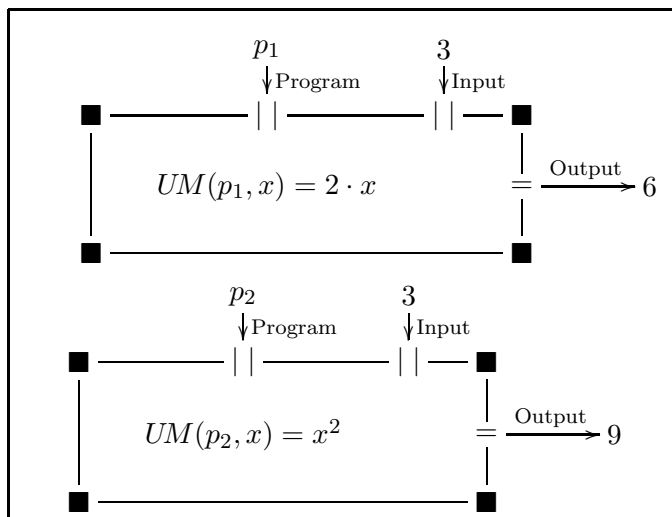

Table 3. Two *ad hoc* machines: M_1 for doubling and M_2 for squaring a number.



Tabel 4. Universal machine UM with programs p_1, p_2 simulating M_1, M_2 respectively.

So p_1 is a code for M_1 and p_2 for M_2 . Since we can consider $M_1(p_2)$ and $M_2(p_2)$, there is interaction: agents acting on a code, in the second case even their own code.

The domain in this case consists of implemented computable functions, i.e. machines ready for a specific computing job to be performed. A code for an element of this domain consists of a program that simulates the job on a universal machine. The program of a computable function is not yet active, not yet executable in computer science terminology. Only after decoding does a program come into action. Besides coding, interaction is also present. In the universal machine the program and the data are usually kept strictly separate. But this is not obligatory. One can make the program and the input data overlap so that after running for a while on the universal computer, the initial program is modified.

4. Mathematical theorems. A final example in this section is concerned with mathematics. A mathematical theorem is usually about numbers or other abstract entities. Gödel introduced codes for mathematical statements and used as code-set the collection $\{0, 1, 2, 3, \dots\}$ of natural numbers, that do not have any assertive power. As a consequence, one can formulate in mathematics not only statements about numbers, but via coding also

about other such statements. There are even statements that speak about themselves. Again we see that both the coding and interaction aspects of reflection are present.

The power of reflection

The mentioned examples of reflection all have quite powerful consequences.

We know how dramatically life has transformed our planet. Life essentially depends on the DNA coding of proteins and the fact that these proteins can modify DNA. This modification is necessary in order to replicate DNA or to proof-read it preventing fatal errors.

One particular species, *homo sapiens*, possesses language. We know its dramatic effects. Reflection using quoting is an essential element in language acquisition. It enables a child to ask questions like: “Mother, what is the meaning of the word ‘curious’?”

Reflection in computing has given us the universal machine. Just one design² with a scala of possibilities through software. This has had a multi-trillion US\$ impact on the present stage of the industrial revolution of which we cannot yet see all the consequences.

The effects of reflection in mathematics are less well-known. In this discipline there are statements of which one can see intuitively that they are true, but a formal proof is not immediate. Using reflection, however, proofs using intuition can be replaced by formal proofs³, see Howe [1995] and Barendregt [1997], pp. 21-23. Formal provability is important for the emerging technology of interactive (human-computer) theorem proving and proof verification. Such formal and machine-checked proofs are already changing the way hardware is being constructed⁴ and in the future probably also on the way one will develop software. As to the art of mathematics itself, it will bring the

²That there are several kinds of computers on the market is a minor detail: this has to do with speed and user-friendliness.

³Often an opposite claim is based on Gödel’s incompleteness result. Given a mathematical theory \mathcal{T} containing at least arithmetic that is consistent (expressed as $\text{Con}(\mathcal{T})$), incompleteness states the following. There is a statement G (equivalent to ‘ G is not provable’) within the language of \mathcal{T} that is neither provable nor refutable in \mathcal{T} , but nevertheless valid, see Smullyan [1992]. It is easy to show that G is unprovable if \mathcal{T} is consistent, hence by construction G is true. So we have informally proved that G follows from $\text{Con}(\mathcal{T})$. Our (to some unconventional) view on Gödel’s theorem is based on the following. By reflection one also can show formally that $\text{Con}(\mathcal{T}) \rightarrow G$. Hence it comes not as a surprise, that G is valid on the basis of the assumed consistency. This has nothing to do with the specialness of the human mind, in which we believe but on different grounds, see the section ‘Reflection in spirituality’.

⁴Making it much more reliable.

technology of Computer Algebra (dealing exactly with equations between symbolic expressions involving elements like $\sqrt{2}$ and π) to the level of arbitrary mathematical statements (involving more complex relations than just equalities between arbitrary mathematical concepts).

The other side of reflection

Anything that is useful and powerful (like fire), can also have a different usage (such as arson). Similarly the power of reflection in the four given examples can be used in different ways.

Reflection in the chemistry of life has produced the species, but also it has as consequence the existence of viruses. Within natural language reflection gives rise to learning a language, but also to paradoxes⁵. The universal computer has as a consequence that there are unsolvable problems, notably the ones we are most interested in⁶. Reflection within mathematics has as a consequence that for almost all interesting consistent axiomatic theories, there are statements that cannot be settled (proved or refuted) within that theory (Gödel's incompleteness result mentioned above).

We see that reflection may be compared to the forbidden fruit: it is powerful, but at the same time, it entails dangers and limitations as well. A proper view of these limitations will make us more modest.

Reflection in spirituality

Insight (*vipassana*) meditation, which stems from classical Buddhism, concerns itself with our consciousness. When impressions come to us through our senses, we obtain a mental representation (e.g. an object in front of us). Now this mental image may be *recollected*: this means that we obtain the awareness of the awareness, also called *mindfulness*. In order to develop the right mindfulness it should be applied to all aspects of consciousness. Parts that usually are not seen as content, but as a coloring of consciousness, become just as important as the object of meditation. If a leg hurts during meditation, one should be mindful of it. Moreover, one learns not only to see the pain, but also the feelings and reactions in connection to that pain. This fine-grained mindfulness will have an 'intuitive analytic' effect: our mind becomes decomposed into its constituents (input, feeling, cognition, conditioning and awareness). Seeing this, we become less subject

⁵Like 'This sentence is false.'

⁶'Is this computation going to halt or run forever?' See Yates [1998]

to various possible vicious circles in our body-mind system that often push us into greed, hatred or compulsive thinking.

Because mindfulness brings the components of consciousness to the open in a disconnected, bare form, they are devoid of their usual meaning. The total information of ordinary mental states can be reconstructed from mindfulness. That is why it works like coding with the contents of our consciousness as domain.

The reflective rôle of mindfulness on our consciousness is quite similar to that of quoting in ordinary language. As proteins can purify part of our DNA, the insight into the constituents of consciousness can purify our mind. Mindfulness makes visible processes within consciousness, hitherto unseen. After that, mindfulness serves as a protection by not letting the components of consciousness exercise their usual meaning. Finally, the presence of mindfulness reorganizes consciousness, giving it a degree of freedom greater than before. Using mindfulness one may act, even if one does not dare; or, one may abstain from action, even if one is urged. Then wisdom will result: morality not based on duty but on virtue. This is the interaction of consciousness and mindfulness. Therefore, by our definition, one can speak of reflection.

This power of reflection via mindfulness also has another side to it. The splitting of our consciousness into components causes a vanishing of the usual view we hold of ourselves and the world. If these phenomena are not accompanied in a proper way, they may become disturbing. But during the intensive meditation retreats the teacher pays proper attention to this. With the right understanding and reorganization, the meditator obtains a new stable balance, as soon as one knows and has incorporated the phenomena.

Mental disorders related to stress can cause similar dissociations. Although the sufferers appear to function normally, to them the world or worse their person does not seem real. This may be viewed as an incomplete and unsystematic use of mindfulness. Perhaps this explains the enigma of why some of the sufferers become 'weller than well', as was observed in Menninger [1963]. These cured patients might very well have obtained the mental purification that is the objective of vipassana meditation.

Pure Consciousness

In Hofstadter [1979] the notion of 'strange loop' is introduced: 'Something that contains a part that becomes a copy of the total when zoomed out. 'Reflection' in this paper is inspired by that notion, but focuses on a special aspect: zooming out in reflection works via the mechanism of coding. The

main thesis of Hofstadter is that ‘strange loops’ are at the basis of self-consciousness. I partly agree with this thesis and would like to add that mindfulness serves as the necessary zooming mechanism in the strange loop of self-consciousness. On the other hand, the thesis only explains the ‘self’ aspect, the consciousness part still remains obscure. I disagree with the title of Dennet [1993]: ‘Consciousness explained’. No matter how many levels of cognition and feedback we place on top of sensory input in a model of the mind, it *a priori* seems not able to account for experiences. We always could simulated these processes on an oldfashioned computer consisting of relais, or even play it as a social game with cards. It is not that I object to base our consciousness on outer agents like the cardplayers (we depend on nature in a similar way). It is the claimed emergence of consciousness as a side effect of the cardgame that seems absurd.

Spiritual reflection introduces us to awareness beyond ordinary consciousness, which is without content, but nevertheless conscious. It is called *pure consciousness*. This phenomenon may be explained by comparing our personality to the images on a celluloid film, in which we are playing the title role of our life. Although everything that is familiar to us is depicted on the film, it is in the dark. We need light to see the film as a moovie. It may be the case that this pure consciousness is the missing explanatory link between the purely neurophysiological activity of our brain and the conscious mind that we (at least think to) possess. This pure light is believed to transcends the person. The difference between you and me is in the matter (cf. the celluloid of the film). That what gives us awareness is said to come from a common source: the pure consciousness acting as the necessary ‘light’.

To understand where this pure consciousness (our inner light) comes from we may have to look better into nature (through a new kind of physics, see e.g. Chalmers [1996] or Stapp [1996]) or better into ourselves (through insight meditation, see e.g. Goldstein [1983]). Probably we will need to do both.

References

- Alberts, B. et al. [1994] *The Cell*. Garland.
Barendregt, H. [1997] The impact of the lambda calculus,
Bulletin of Symbolic Logic, Volume 3, no 2, 181–215.
Chalmers, D. [1996] *The Conscious Mind, Towards a Fundamental Theory*,
Oxford University Press.
Dennet, D.C. [1993] *Consciousness Explained*. Penguin Books.
Harrison, J. [1995] Metatheory and Reflection in Theorem Proving:

- A Survey and Critique, available at
<http://www.cl.cam.ac.uk/users/jrh/papers/reflect.dvi.gz>
- Goldstein, J. [1983] *The Experience of Insight*, Shambhala, Boston, London.
- Hofstadter, D. [1979] *Gödel Escher Bach*. Harvester Press.
- Howe, D.J. [1992] Reflecting the semantics of reflected proof, in: *Proof Theory*, Aczel *et al.* (eds.), Cambridge University Press, 229–250.
- Menninger, K., M. Mayman and P. Pruyser [1963] *The Vital Balance. The Life Process in Mental Health and Illness*. Viking.
- Peitsch, M.C., D.R. Stampf, T.N.C. Wells, J.L. Sussman [1995] The Swiss-3DImage collection and PDB-Browser on the World-Wide Web. *Trends in Biochemical Sciences* 20, 82-84. See also: <http://www.expasy.org>
- Smullyan, R. [1992] *Gödel's Incompleteness Theorems*. Oxford University Press.
- Stapp, H. [1996] The Hard Problem: A Quantum Approach. *Journal of Consciousness Studies*, 3 (3), 194–210.
- Tarski, A. [1933/1995] *Introduction to Logic*. Dover.
- Yates, M. [1998] What computers can't do. *+Plus*, issue 5, available at <http://plus.maths.org/issue5/index.html>.

Acknowledgement. Reprinted with permission of Templeton Foundation Press from the forthcoming *Spiritual Information*, edited by Charles L. Harper, Jr., © 2003. I thank the desk editor Pamela Bond for useful linguistic suggestions.

About the Author

Hendrik P. Barendregt received his Ph.D. for a thesis in Mathematical Logic in 1971 from Utrecht University. From 1972 to 1979, he studied Zen meditation with Kobun Chino Roshi (1938-2002) in California, and from 1977 to the present he has been studying Vipassana meditation with Most Venerable Phra Mettavihari in Amsterdam. His publications in the field of mathematical logic and theoretical computer science are frequently cited; among the best known are *The Lambda Calculus, Its Syntax and Semantics*, Elsevier, 1984 and "Lambda Calculi with Types," in *Handbook of Logic in Computer Science*, Vol. II, Oxford University Press (1992), 117-309. He has received substantial personal research funds from Nijmegen University (1997) and also the Spinoza award in 2002 given by the Dutch National Science Foundation (NWO). He holds memberships in the Academia Europaea, the Hollandsche Maatschappij der Wetenschappen, and, since 1997, the Royal Dutch Academy of Sciences. At present Barendregt occupies the Chair in Foundations of Mathematics and Computer Science at Nijmegen University.

Meditation is the process of redirecting your thoughts to calm your mind. It may also improve your overall quality of life. This is what the research says. The popularity of meditation is increasing as more people discover its many health benefits. You can use it to increase awareness of yourself and your surroundings. Many people think of it as a way to reduce stress and develop concentration. People also use the practice to develop other beneficial habits and feelings, such as a positive mood and outlook, self-discipline, healthy sleep patterns, and even increased pain tolerance. This article reviews 12 health benefits of meditation.

1. Reduces stress. Stress reduction is one of the most common reasons people try meditation. A fifth place in which reflection occurs is our spiritual development. In all of these cases the effects of reflection are powerful, even downright dramatic. We should be aware of these effects and use them in a responsible way.

Reflection: domain, coding and interaction

Reflection occurs in situations in which there is a domain of objects that all have active meaning, i.e. specific functions within the right context. Before turning to the definition itself, let us present the domains relevant for the four examples. The first domain is the class of proteins. These have indeed specific functions within a living or Reflection and its Use with a focus on languages and lambda calculus

Henk Barendregt NIII, Nijmegen University The Netherlands Schakelblok Informatica voor Biologen Winter 2004 Contents 1 Overview 3 2 Languages 12 3 Combinatory Logic 25 4 Lambda calculus 30 5 Self-reflection 37

1. Overview The phenomenon of reflection will be introduced and clarified by examples. Based on the chapter "Reflection and its use, from Science to Meditation"™, in *Spiritual Information*, edited by Charles L. Harper, Jr., © 2004, Templeton Foundation Press.
2. Languages Describing and generating languages is an important subject of study. Formal languages are precisely defined via logical rules.